

MEDIUM DUTY MOBILE SCISSOR TABLES

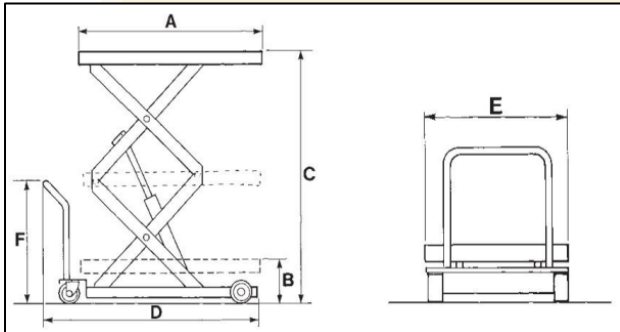

Single scissor									
Operation	Capacity (KG)	(C) Raised height mm	(B) Closed height mm	(E x A) Platform width x length mm	(E x D) overall width x length mm	(F) Handle height mm	Approx weight (KG)	Reference	Approx lift time
Manual	300Kg	840	335	500 x 840	500 x 1050	860	83	SC-300-S-M	18 pumps
Electric	300kg	840	335	500 x 840	500 x 1130	860	130	SC-300-S-E	9 seconds
Manual	500kg	900	340	610 x 1030	610 x 1320	925	109	SC-500-S-M	40 pumps
Electric	500kg	900	340	610 x 1030	610 x 1330	925	158	SC-500-S-E	12 seconds

Double scissor									
Operation	Capacity (KG)	(C) Raised height mm	(B) Closed height mm	(E x A) Platform width x length mm	(E x D) overall width x length mm	(F) Handle height mm	Approx weight (KG)	Reference	Approx lift time
Manual	125kg	1420	430	500 x 840	500 x 1090	860	100	SC-125-D-M	19 pumps
Electric	125kg	1420	430	500 x 840	500 x 1130	860	147	SC-125-D-E	9 seconds
Manual	300kg	1350	295	590 x 840	640 x 1190	900	110	SC-300-D-M	25 pumps
Electric	300kg	1350	295	590 x 840	640 x 1190	900	147	SC-300-D-E	15 seconds
Manual	450kg	1550	295	610 x 1030	665 x 1350	910	143	SC-450-D-M	71 pumps
Electric	450kg	1550	295	610 x 1030	665 x 1350	910	190	SC-450-D-E	26 seconds

Optional extra's

- Stainless Steel top cover
- Plastic roller conveyor top (Increases closed/raised height by 60mm)
- Ball top
- Bellows safety skirt
- Rubber Mat



Features (all models)

- Safe, light, easy to use and highly manoeuvrable
- High quality robust construction
- A range of maximum lift heights from 840mm to 1550mm
- Manual or battery electric operation
- Optional extras from stainless steel lid to bellows skirt
- Quality British design and manufacture
- Single or double lifts available
- Heavy duty arm, bearings and hydraulics
- All wheels are fitted with sealed bearings and polyurethane tyres
- 2 swivel castors fitted with a total stop brake as standard
- All models fitted with an overload valve and slow lowering valve to control lowering speed
- A unique lift up table top allows safe and easy maintenance- can only be lifted when table is in a closed position
- Each table is issued with operating instructions and a test certificate in conformance with EU Standards EN 1570 and BS:5323:1980

Features (Battery electric models)

- Models include 12v traction battery and charger
- Safety cut-off bar fitted to the underside of the platform stops table from lowering in the case of an obstruction
- Remote push button control up/down operation
- Emergency stop switch
- Safe design plug-in charger
- Strong electrical flex
- Electrical contacts/motors conform to EQ1570/ EN 60529

Warning

- Scissor tables are NOT designed to carry people- special safety features would be required in accordance with EN1570
- Tables which carry wheeled loads or rolling loads must be fitted with a device to prevent these rolling off
- Mobile tables are designed to be propelled by pedestrians, if any other means are to be used, please use precautions in accordance with EN1570
- The rated load of the table must not be exceeded as this can cause damage to the table. The load must be evenly distributed on the table surface for stability